

TRADE OF
Pipefitting

PHASE 2

Module 5

Technical Drawing

UNIT: 4

Drawings for Pipe Installation

Produced by

SOLAS

An tSeirbhís Oideachais Leanúnaigh agus Scileanna
Further Education and Training Authority

In cooperation with subject matter expert:

Finbar Smith

© SOLAS 2014

Table of Contents

Unit Objective	1
Learning Outcome	2
1.0 System drawings (PFDs and P&IDs).....	3
1.1 Process Flow Drawing (PFD).....	3
1.2 Process and Instrumentation Drawing (P&ID)	4
2.0 Drawing Practical.....	6
2.1 Exercise No. 2.5.4a.....	7
2.2 Exercise No. 2.5.4b.....	8
2.3 Exercise No. 2.5.4c.....	10
Exercises.....	12
Additional Resources.....	13

Unit Objective

There are five units in Module 5. Unit 1 focuses on Drawing Methods & Types, Unit 2; Standard Drawing Conventions, Unit 3; Drawing Equipment & Practice, Unit 4; Drawings for Piping Installation, Unit 5; Traceability Record.

In this unit you will be introduced to Drawings for Pipe Installation.

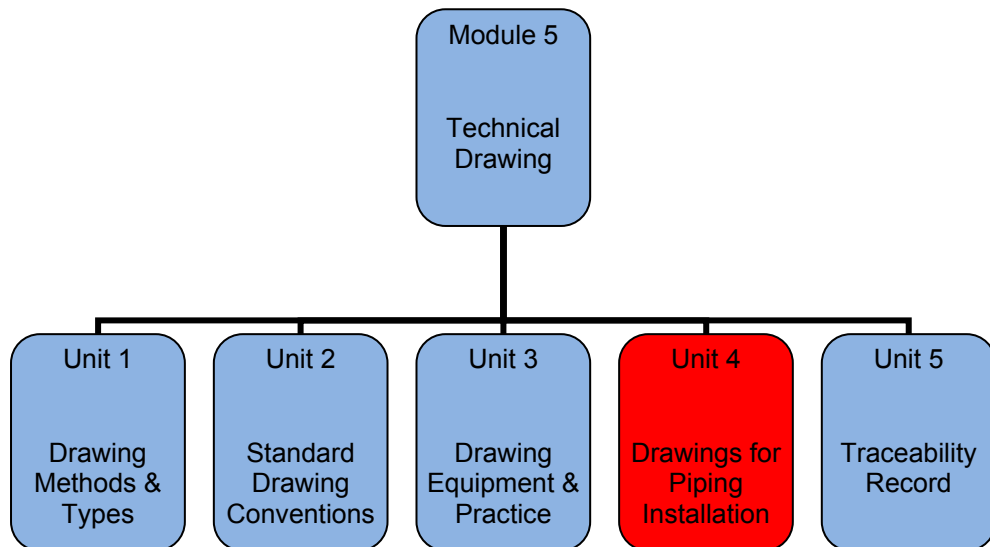

Learning Outcome

By the end of this unit each apprentice will be able to:

- Identify and draw Piping and Instrument Diagram (P&ID) symbols frequently used for valves instruments and equipment as per Exercise No. 2.5.4a
- Identify and draw isometric symbols used for piping systems i.e. screwed, butt welded as per Exercise No. 2.5.4b
- Identify and draw pipe General Arrangement (GA) symbols that are used for piping general arrangement drawings as per Exercise No. 2.5.4c
- Sketch single line piping isometric for 2 of the piping assembly spools
- Dimension and label single line piping isometric drawings
- Sketch correct piping GA views for 2 of the piping assembly spools

1.0 System drawings (PFDs and P&IDs)

Key Learning Points

- Identify the function of a Process Flow Drawing (PFD)
- Identify the function of a Process and Instrumentation Drawing (P&ID)

1.1 Process Flow Drawing (PFD)

A process flow diagram (PFD) is a diagram commonly used in chemical and process engineering to indicate the general flow of plant processes and equipment. The PFD displays the relationship between major equipment of a plant facility and does not show minor details such as piping details and designations. Typically, process flow diagrams of a single unit process will include the following:

- Process piping
- Major equipment items
- Control valves and other major valves
- Connections with other systems
- Major bypass and recirculation streams
- Operational data (temperature, pressure, mass flow rate, density, etc.).
- Process stream names

Process flow diagrams generally do not include:

- Pipe classes or piping line numbers
- Process control instrumentation (sensors and final elements)
- Minor bypass lines
- Isolation and shutoff valves
- Maintenance vents and drains
- Relief and safety valves
- Flanges

Process flow diagrams are high levels drawings usually of multiple process systems within a large industrial plant and may be called block flow diagrams or schematic flow diagrams. Figure 1 illustrates a typical PFD for an evaporator system.

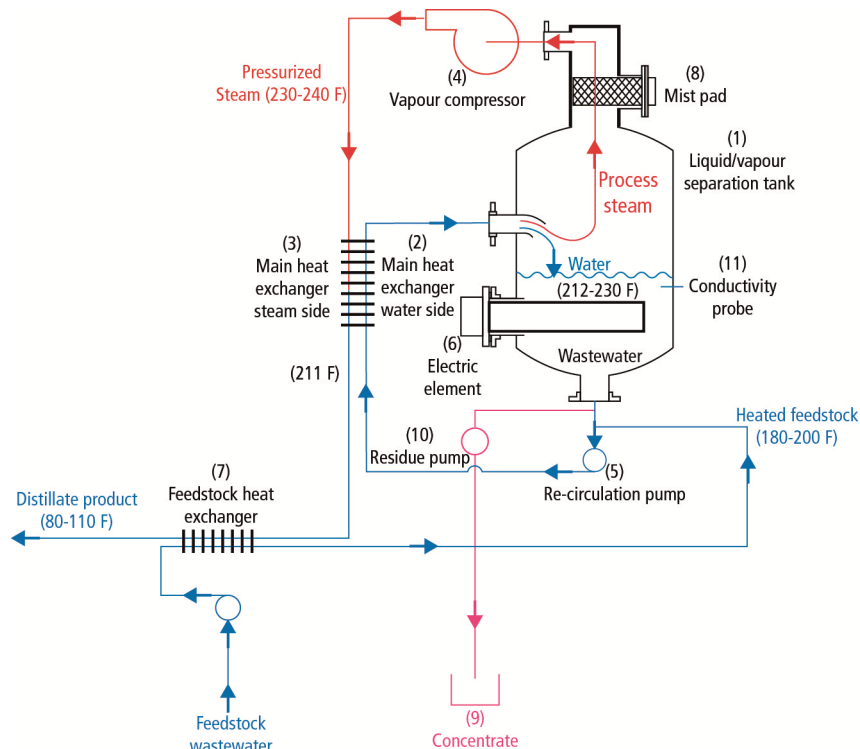

Figure 1 – PFD of Typical Evaporator system

1.2 Process and Instrumentation Drawing (P&ID)

The P&ID shows the interconnection of process equipment and the instrumentation used to control the process. In the process industry, a standard set of symbols is used to prepare P&ID drawings of processes as can be seen in Figure 2 below. For processing facilities, a P&ID is a pictorial representation of the following:

- Key piping and instrument details
- Relationship between control instruments and process equipment
- Control and shutdown schemes
- Safety and regulatory requirements
- Basic start up and operational information

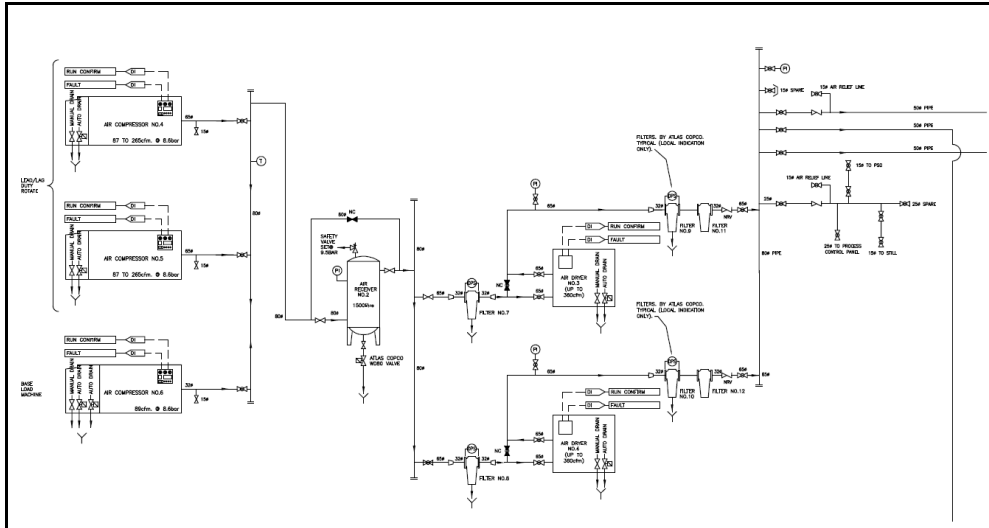

Figure 2 – P&ID of Typical compressed air system

As a rule P&IDs do not have a drawing scale and present only the relationship or sequence between components. Just because two pieces of equipment are drawn next to each other does not indicate that in the plant the equipment is even in the same building; it is just the next part or piece of the system. These drawings only present information on how a system functions, not the actual physical relationships. Because P&IDs provide the most concise format for how a system should function, they are used extensively in the operation, repair, and modification of the plant.

2.0 Drawing Practical

Key Learning Points

- Identify and draw Piping and Instrument Diagram (P&ID) symbols frequently used for valves instruments and equipment
- Identify and draw isometric symbols used for screwed and butt welded fittings for piping systems.
- Identify and draw pipe General Arrangement (GA) symbols that are used for piping general arrangement drawings
- Sketch single line piping isometric for 2 of the piping assembly spools from Phase 2, Module 4, Unit 6.
- Dimension and label these single line piping isometric drawings
- Sketch correct piping GA views for 2 of the piping assembly spools from Phase 2, Module 4, Unit 6.

Practical Task

This is a practical task. Please refer to relevant sections of the course notes and your instructor for additional information and instruction.

2.1 Exercise No. 2.5.4a

Pipefitting

Phase 2

Code XX

Module 5: Unit 4

Exercise No. 2.5.4a

Instructions

Identify symbols shown on drawing

Tools and Materials

Information sheets on plumbing/heating symbols

DIMENSIONS	REVISION #	SCALE	MATERIAL	ISSUED
-	-	-	-	25/46
TITLE				FILE
DRAWING				PH 5
MOD 4				SHEET 1 OF 1 SHEETS
				mm

Standards All plumbing/heating symbols correctly identified

2.2 Exercise No. 2.5.4b

Pipefitting → Phase-2 → Code-nn

Module 5: Unit-4

Exercise No. 2.5.4b

Instructions

- Sketch the butt-weld symbol in the left-hand column
- Sketch the threaded symbol in the middle column
- Sketch the socket-weld symbol in the right-hand column
- Complete all symbols
- Sign and date the form

Tools and Materials

Blank piping isometric symbols sheet as per exercise 2.5.4b printed on A4 paper

Standards

- Minimum 4 butt-weld symbols drawn correctly
- Minimum 4 threaded-weld symbols drawn correctly
- Minimum 4 socket-weld symbols drawn correctly
- Sheet signed and dated correctly
- Sheet kept clean and presentable
- All writing neat and legible

Piping Isometric Symbols			
Item	Butt Weld	Threaded	Socket weld
Elbow 90°			
Elbow 45°			
Tee			
Flange			
Reducer			
Ball Valve			

Name: _____ Date: _____

















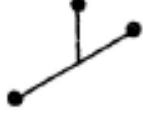

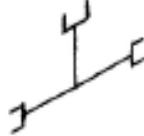
<i>Item</i>	<i>Butt Weld</i>	<i>Threaded</i>	<i>Socket weld</i>
Elbow 90°			
Elbow 45°			
Tee			
Flange			
Reducer			
Ball Valve			

Figure 3 – Common Isometric Pipe symbols

2.3 Exercise No. 2.5.4c

Pipefitting → Phase-2 → Code-000

Module-5: Unit-4

• Exercise No. 2.5.4c

• Instructions

- Sketch the piping GA symbols in the left hand column
- Sketch the corresponding isometric view where applicable in the right hand column
- Complete all symbols
- Sign and date the form

• Tools and Materials

- Blank Piping GA Symbols sheet as per exercise 2.5.4c printed on A4 paper
- GA Pipe symbols reference sheet

• Standards

- Minimum 4 piping GA symbols drawn correctly
- Minimum 4 isometric views drawn correctly
- Sheet signed and dated correctly
- Sheet kept clean and presentable
- All writing neat and legible

Piping GA Symbols		
Item	Piping GA Symbol	Isometric View
End of Pipe		
Line Break		
Reducer		
Valve		
Elbows		
Tee under line		
Tee over line		

Name: _____ Date: _____









<i>Item</i>	<i>Piping GA Symbol</i>	<i>Isometric View</i>
End of Pipe		
Line Break		
Reducer		
Valve		
Elbows		
Tee under line		
Tee over line		

Figure 4- Common GA Pipe symbols

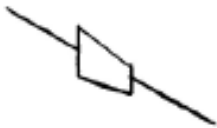
Exercises

- Identify and draw Piping and Instrument Diagram (P&ID) symbols frequently used for valves instruments and equipment as per Exercise No. 2.5.4a
- Identify and draw isometric symbols used for piping systems i.e. screwed, butt welded as per Exercise No. 2.5.4b
- Identify and draw pipe General Arrangement (GA) symbols that are used for piping general arrangement drawings as per Exercise No. 2.5.4c
- Sketch single line piping isometric for 2 of the piping assembly spools from Phase 2, Module 4, Unit 6.
- Dimension and label these single line piping isometric drawings
- Sketch correct piping GA views for 2 of the piping assembly spools from Phase 2, Module 4, Unit 6.

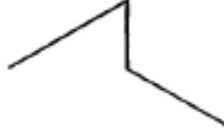
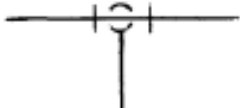
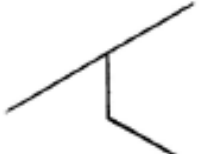
Additional Resources

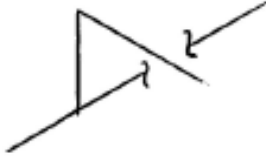
Title	Author	Ref. Code
The Induction Book, “ <i>Code of Behaviour & Health & Safety Guidelines</i> ”	SOLAS	
Basic Welding and Fabrication	W Kenyon	ISBN 0-582-00536-L
Fundamentals of Fabrication and Welding Engineering	FJM Smith	ISBN 0-582-09799-1
<i>Workshop processes, practices and materials</i> , 3 rd edition, Elsevier Science & Technology	Black, Bruce J 2004	ISBN-13: 9780750660730
New Engineering Technology	Lawrence Smyth & Liam Hennessy	ISBN 086 1674480

Videos:

- Understanding welding fumes
- Welder on Site...Be Aware (Vocam)
- Powered hand tool safety (Vocam)
- Industrial Ergonomics (Vocam)

Available from:

Vocam Ireland

Circle Organisation Ltd

Friar Street, Thurles, Co Tipperary, Ireland

Tel: +353 504 24666

S O L A S

An tSeirbhís Oideachais Leanúnaigh agus Scileanna
Further Education and Training Authority

*Castleforbes House
Castleforbes Road
Dublin 1*